

### 1) Introduction

- a) The following document is intended for the explicit use of PSC Couplings' customers to aid in the installation of PSC G Series disc couplings.
- b) PSC's couplings are designed to withstand the toughest environments while providing reliable mechanical connections. It is very important to following the instructions set for in this manual to insure the longest life possible from your coupling.
- c) Although the coupling may have been properly specified during the design and selection process before the coupling was ordered, operational conditions could possibly have changed prior to installation. PSC provides the information and technical support necessary to ensure the appropriate coupling selection was made relative to the product specifications. The end user is ultimately responsible for verifying the suitability of the final coupling selection based on the actual service conditions at the time the coupling is installed. Correct installation and alignment practices will ensure longer coupling life, trouble free operation, and a safer operating environment for the coupling.
- d) Please thoroughly review all instructions in this document prior to installing this coupling and placing it in operation. Proper safety guidelines and practices should always be followed during every phase of the installation. This installation document is considered part of the purchased product and should be retained for future reference.
- e) If there are any questions, please contact us at [service@psc couplings.com](mailto:service@psc couplings.com). For highly engineered

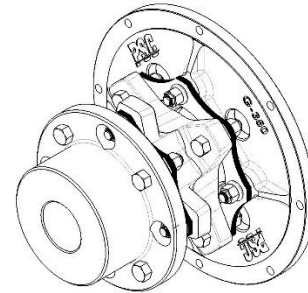

Figure 1: G Series 350 GC

- couplings or customer specials, PSC will provide an engineering drawing containing special installation instructions that supersede this document.
- f) Look for the following Statements when special care is to be followed and understood:

**\*\*WARNING\*\*** – This statement means that not following this recommendation could result in bodily harm.

**\*\*CAUTION\*\*** – This statement means that not following this recommendation could result in a damaged product or equipment.

**\*\*ATTENTION\*\*** – This is a statement of alert, requiring special attention to a process or measurement require for installation.

### 2) Safety

**\*\*WARNING\*\*** Safety is a top priority at PSC. Please pay attention to the following statements:

- a) Accidents involving rotating equipment may result in loss of life, serious bodily harm, or property damage. The purchaser of this equipment must assure that the equipment is properly assembled, installed, safeguarded, operated, and maintained.
- b) This equipment should never be operated at, or subjected to, conditions that exceed manufacturer's specifications. Consult all applicable Federal, State and local laws and regulations covering the safe operation and maintenance of equipment, including, without limitation, the USDOL-OSHA "Lockout/Tag-out" procedure set forth in 29 CFR 1910.147.
- c) Because of the possible danger to persons or property from accidents which may result from the improper use or unapproved modifications of the product, this product must be installed, maintained and operated in accordance with the procedures, standards, and engineering specifications specified in the product literature. To assure safe operation, this product should be inspected in accordance with the instructions described in this document. Proper guards and any suitable safety equipment or procedures as may be necessary, or as may be specified in safety codes, should be installed by the user. Safety equipment,
  - i) coupling guards, and shields are not provided by, nor are they the responsibility of PSC.
- d) Do not touch any coupling or rotating equipment when it is in operation.
- e) Only skilled professionals should install couplings. These Maintenance and installation instructions should be readily available during the onsite installation of any PSC G Series coupling.
- f) During operation all rotating couplings must have coupling guards installed that comply with whatever local standard is the rule of law in the geographical vicinity where the coupling is being installed.
- g) All PSC G Series couplings and replacement parts should be stored in a protected environment to prevent damage which may prematurely compromise the coupling during its life span.
- h) For ATEX requirements the guard must have a minimum of 12.7 mm (1/2 in) radial clearance to the coupling outside diameter and allow for proper ventilation.
- i) Follow all static dissipative requirements when working in sensitive areas. Packaging can hold static charges so be sure to remove outside of critical areas.
- j) Any work done on the coupling must only occur when the coupling has zero stored energy.

- k) Do not engage the drive system without fully assembling all coupling components. If the equipment is started with only a hub attached, the hub must be ready for normal operation, with the key and set screw (if included) fastened.
- l) When the full coupling assembly is started, all fasteners and hardware must be completely and properly secured.

**\*\*WARNING\*\* DO NOT RUN THE COUPLING WITH OUT ALL FASTENERS TORQUED TO PROPER LEVELS**

- m) Follow DIN EN 1127-1:2008:02, Annex A. for any explosive tool requirements.
- n) The coupling may only be used in accordance with the technical data provided in the PDC disc coupling catalog.

**\*\* WARNING \*\* DO NOT MODIFY ANY PART OF THE G SERIES DISC COUPLING FOR ANY REASON**

- o) Any spare parts for service or replacement must come from or be approved by PSC.

**3) PSC G Series Coupling Component Parts**

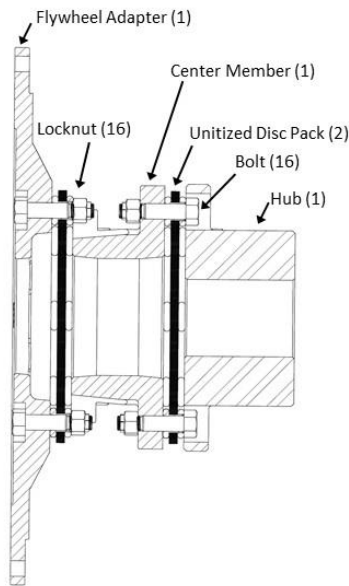

Figure 2: GC Model

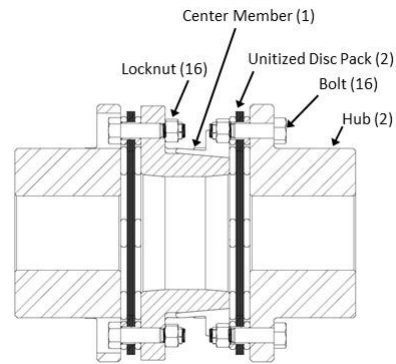

Figure 3: GA Model

**4) Inspection & Preparation**

- a) Proper care in installing and aligning will permit couplings to operate to full capacity, compensate for mis-alignment and provide very good service life.
- b) Examine all coupling parts to ensure there is no visible damage.
- c) Inspect shafts and hub(s) bores and make sure they are free from burrs.
- d) Move the equipment to be connected into position. Set the gap to the required distance between shaft ends, DBSE dimension. See Fig. 2 or 3 and Table 2



Figure 4: Mounting Hubs on Shafts

#### 5) Hub Mounting - General

- a) Clean the hub bores and shafts using lint free cloth and a light solvent or degreaser. Remove any nicks or burrs.
- b) The key should have a snug fit in the hub and shaft, with a slight clearance over the top of the key when assembled.
- c) Hub Heating Options for Interference Fit (straight or tapered):

**\*\*CAUTION\*\*** Oven Heating is the preferred method. Heating keyed interference fit hubs to 350° F (177° C) is usually sufficient. Parts can be heated to higher temperatures, usually 450° F to 600° F (232° C to 316° C). 600° F is the maximum temperature where the steel hub does not go through an annealing process and yet can still be handled with heat resistant gloves. When heating the hubs in an oven, place them on a rack and do not rest the hubs on the oven surface. The hubs should remain in the oven for a sufficient period of time to heat the hub all the way through.

**\*\*WARNING\*\*** Do not spot heat the hub as distortion may occur. Open Flame Heating is typically not

recommended. If the hub is being heated with an oxyacetylene, or blow torch, use an excess acetylene mixture. Mark the hub body at the top, center, and bottom along the length of the hub with heat resistant crayons, one with a 350° F (177° C) melt temperature and another with a 450° F (232° C) melt temperature. The hub should be sitting elevated on refractory bricks oriented to allow the flame to flow through the hub. With a “Blue Flame” or “Rosebud” torch, direct the flame towards the hub bore using constant motion to avoid overheating any single area. Once the heat sensitive crayon marks melt, the hub should be ready for mounting.

Higher temperatures may be required for higher interference fit levels where alloy steel hubs may be encountered. A general rule to consider is that for every 160°F increase in temperature, steel will expand 0.001 inch for every inch of shaft diameter (or 0.029 mm/100°C). When calculating temperatures, also consider additional expansion to provide clearance and allow for a loss of heat and subsequent shrinkage during the handling process.

#### 6) Straight Bore with Clearance/Slip Fit

- a) Install the key in the shaft.
- b) Install the set screw(s) in the hub and check to make sure the set screw is not protruding into the keyway. Then slide the hub up the shaft to desired axial position (normally with hub flange face flush with shaft end).
- c) Tighten the set screw(s) using a calibrated torque wrench to the values shown in Table 1.
- d) **\*\*CAUTION\*\***! Never use two set screws with one on top of the other in the same tapped hole.

Table 1: Set Screw Tightening Torque

Set Screw Size	#10-32	1/4-20	3/8-16	1/2-13	5/8-11	3/4-10	1-8
Hex Head Key Size	3/32	1/8	3/16	1/4	5/16	3/8	9/16
Tightening Torque	(Nm)	4.5	10.6	35	84	165	285
	(ft-lb)	3.3	7.8	26	62	122	210

Set Screw Size	M5	M6	M10	M12	M16	M20	M24
Hex Head Key Size	2.5	3	5	6	8	10	12
Tightening Torque	(Nm)	4.7	7.7	35	55	125	250
	(ft-lb)	3.5	5.7	26	41	92	184

#### 7) Straight Bore with Interference Fit

- a) Accurately measure the bore and shaft diameters to assure a proper interference fit.
- b) Install the key in the shaft.
- c) Follow hub heating options in section 5.
- d) With the hub thermally expanded for sufficient clearance with the shaft, quickly install on to the shaft to desired axial position (normally with hub flange face flush with shaft end). A pre-set axial stop device can be helpful.

#### 8) Taper Bore with Interference Fit

- a) Put the hub on the shaft without the key(s) in place and lightly tap the hub on the shaft with a soft hammer. This will assure a metal-to-metal fit between shaft and hub. This is the starting point for the axial draw. Record the position between shaft end and hub face with a depth micrometer. Mount a dial indicator to read axial hub movement. Set the indicator to "0".

- b) Remove the hub and install the key(s) in the shaft.
- c) Follow hub heating options in section 5.
- d) With the hub thermally expanded for sufficient clearance with the shaft, quickly install hub on to the shaft to the "0" set point. Continue to advance the hub up the taper to the desired axial position. Use the indicator as a guide only. A pre-set axial stop device can be helpful. Check the final results with a depth micrometer. Install the hub retention device to hold the hub in place.

#### 9) Shaft Alignment

- a) Soft Foot. The equipment must sit flat on its base. Any soft foot must now be corrected.
- b) Axial Spacing. The axial spacing of the shafts should be positioned so that the disc packs (flexing elements) are flat when the equipment is running under normal operating conditions. This means there is a minimal amount of waviness in the disc pack when viewed from the side. This will result in a flexing element that is centered and parallel to its mating flange faces. Move the connected equipment to accomplish the above. Refer to the assembly drawing and the connected equipment installation procedures for specific axial spacing requirements.
- c) As a guide, the "DBSE" dimensions are given for GC and GA couplings, along with dimensional tolerances recommended for initial installation. Additional capacity is available to compensate for thermal and structural movement. Maximum axial capacity values for these couplings are also given. See Table 2 and Figures 2 & 3.
- d) Angular Alignment. Rigidly mount a dial indicator on one hub or shaft, reading the face of the other hub flange, as shown in

- e) Parallel Offset. Rigidly mount a dial indicator on one hub or shaft, reading the other hub flange outside diameter, as shown in Figure 6. Compensate for indicator set-up sag. Rotate both shafts together. Adjust the equipment by shimming and/or moving so that the indicator reading is within Table 2 values.

**NOTE:** If the driver or driven equipment alignment tolerances are more stringent than our recommendations, the driver or driven equipment tolerances should be used. Also, be sure to compensate for thermal movement in the equipment. The coupling is capable of approximately four times our recommended initial installation tolerances for axial misalignment. However, close alignment at installation will provide longer service with smoother operation

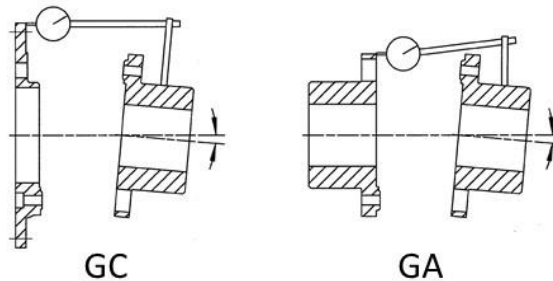

Figure 5: Angular Misalignment

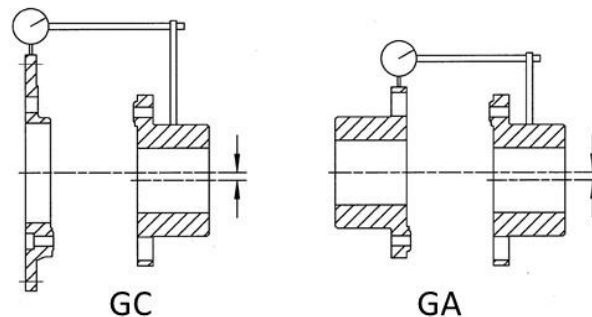

Figure 6: Parallel Misalignment

Table 2: Suggested Maximum Alignment Values

Coupling Size	Total Indicator Reading (T.I.R)			"DBSE" Dimension (in.)			Max. Axial Capacity +/- (in.)
	Angular For GA	Angular For GC	Parallel	GC	GA	Initial Installation Tolerance +/-	
262	0.014	.002 INCHES PER INCH OF "A" DIA.	0.007	4.47	3.51	0.011	0.043
312	0.016		0.008	5.34	4.14	0.013	0.051
350	0.018		0.009	5.89	4.58	0.014	0.056
375	0.020		0.010	6.62	5.18	0.016	0.062
425	0.022		0.011	7.18	5.55	0.017	0.067
450	0.024		0.012	7.68	5.93	0.018	0.072
500	0.027		0.014	8.75	6.81	0.021	0.082
550	0.030		0.015	9.89	7.70	0.023	0.092
600	0.033		0.017	10.89	8.43	0.026	0.102
700	0.038		0.019	12.48	9.66	0.029	0.115
750	0.041		0.021	13.54	10.54	0.031	0.125
800	0.045		0.023	14.74	11.36	0.034	0.136
850	0.047		0.024	15.86	12.18	0.036	0.144
925	0.051		0.026	17.24	13.25	0.039	0.156

### 10) Final Assembly

With the coupling in good alignment, the bolts will fit through the holes in the flanges and the disc packs more easily. See Figures 2 and 3.

#### a) When the flywheel adapter is used – GC Model

- i) On a workbench, or floor, assemble one unitized disc pack to the center member and flywheel adapter, installing all bolts as shown in Figure 2.
- ii) Secure with locknuts and tighten to the torque values shown in Table 3.
- iii) The disc pack, when installed, should look flat and parallel with the mating adapter and center member flange face.
- iv) With the hub mounted and the span length "C" set, proceed to put the sub-assembly (flywheel adapter, unitized disc pack, and center member) into place between the flywheel and hub. Bolt the adapter to the flywheel in the manner prescribed by the engine manufacturer. (Note: Flywheel bolting is not furnished by PSC Couplings.)
- v) Now install the remaining unitized disc pack. Rotate the hub or center member so that the hub bolt holes line up between the center member lugs. It may help with installation of the second unitized disc pack to compress the disc pack on the flywheel adapter side. Use clamps to squeeze the center member toward the flywheel adapter or a pry bar on the other end to push the center member toward the flywheel adapter.
- vi) Start one bolt through a bolt hole in the hub and align it with one of the disc pack holes, and slide the bolt through the disc pack hole. Install a locknut but do not tighten it at this time.
- vii) Pivot the unitized disc pack around until it lines up with the rest of the bolt holes in the hub. Install three more bolts through the remaining hub bolt holes and unitized disc pack. Add the locknuts but do not tighten them.
- viii) Install the remaining four bolts for this end through the hub clearance holes, unitized disc pack and center

member bolt holes. Install locknuts onto the bolts and slightly tighten the locknuts.

The disc pack, when installed should look flat and parallel with the mating hub and center member flange faces.

- ix) Make the final coupling alignment check at this time.
- x) Tighten all the locknuts. See Table 3 for torque values.
- xi) It is recommended that all locknuts be retightened after several hours of initial operation.

NOTE: Due to the locknut body clearances, it may be necessary to use an open end wrench to tighten the locknuts.

#### b) When two hubs are used — GA Model

- i) With the hubs mounted and the span length "C" set, position the center member between the two hubs. Care should be taken when handling the center member. Support the center member on wood blocks, with nylon straps from a hoist, or some other convenient way. It may help to support the end not being worked on with bolts through the center member bolt holes and into the hub flange bolt holes. This will hold the parts in line at that end.
- ii) Rotate the hub or center member that the hub bolt holes line up between the center member lugs.
- iii) Slide one unitized disc pack between the center member and the hub. Install four bolts through the hub bolt holes and unitized disc pack, and four bolts through the hub clearance holes, unitized disc pack, and center member bolt holes as shown in Figure 3. Install a locknut on each bolt and slightly tighten them. The disc pack, when installed, should look flat and parallel with the mating hub and center member flanges.



- iv) Proceed to the second end to install the remaining unitized disc pack. Support the center member and remove the support bolts, if used. Rotate the hub or center member so that the hub bolt holes line up between the center member lugs. It may help with installation of the second unitized disc pack to compress the first disc pack. Use clamps to squeeze the center member toward the first hub or a pry bar on the other end to push the center member ring toward the first hub.
- v) Install the second unitized disc pack and bolts in the same manner as done on the first end. Add the locknuts to these bolts and slightly tighten them. The disc pack, when installed should look flat and parallel with the mating hub and center member flanges.
- vi) Make the final coupling alignment check at this time.
- vii) Tighten the locknuts. See Table 3 for torque values.
- viii) It is recommended that all locknuts be retightened after several hours of initial operation.

Table 3: Locknut Tightening Torques

Coupling Size	Thread Size	Torque		Locknut Wrench Hex Size (in.)	Bolt Head Wrench Hex Size (in.)
		ft-lbs	Nm		
262	3/8-24	43	58	0.56	0.63
312	3/8-24	43	58	0.56	0.69
350	1/2-20	100	136	0.75	0.81
375	1/2-20	100	136	0.75	0.94
425	5/8 -18	175	237	0.94	1.06
450	5/8 -18	175	237	0.94	1.13
500	3/4-16	190*	258*	1.25	1.25
550	7/8-14	255*	346*	1.44	1.44
600	1-14	335*	454*	1.63	1.63
700	1-1/8-12	425*	576*	1.81	1.81
750	1-1/4-12	560*	759*	2.00	2.00
800	1-3/8-12	740*	1003*	2.19	2.19
850	1-1/2-12	950*	1288*	2.38	2.38
925	1-5/8-12	1350*	1830*	2.63	2.63

**Notes:**

1. Torques denoted with (\*) indicates locknuts that are cadmium plated.
2. Lightly oil threads when assembling.
3. Hold bolt head stationary when tightening locknut. Do not tighten by rotating the bolt.
4. Do not use air driven wrenches for bolt/locknut assembly, as heat build-up may cause thread damage.

### 11) Disc Pack Replacement

If it becomes necessary to replace the disc pack, it can be done as follows:

- a) Support the center member.
- b) At the hub end of the coupling, remove all locknuts. Back out and remove all but one bolt. It may be necessary to tap the ends of the bolts with a soft hammer to start them out. Pivot the unitized disc pack out. Remove the last bolt and slide the pack out.
- c) For the GC coupling:
  - i) Remove the bolts that hold the flywheel adapter to the flywheel. Remove the adapter, unitized disc pack, and center member assembly and put it on a bench.
  - ii) Remove all the locknuts and bolts that hold the center member to the disc pack. Remove the center member. Remove the rest of the locknuts and bolts.
  - iii) Replace parts as necessary. Recheck alignment per Section 9. Reassemble per Section 10.
- d) For the GA coupling:
  - i) Now disassemble the other end being sure to support the center member when taking out the last bolts. Remove the center member.
  - ii) Replace parts as necessary.
  - iii) Recheck alignment per Section 9. Reassemble per Section 10.