

### Introduction

- a) The following document is intended for the explicit use of PSC Couplings' customers to aid in the installation of PSC disc couplings.
- b) PSC's couplings are designed to withstand the toughest environments while providing reliable connection between two shafts. It is very important to following the instructions set for in this manual to insure the longest life possible from your coupling.
- c) Although the coupling may have been properly specified during the design and selection process before the coupling was ordered, operational conditions could possibly have changed prior to installation. PSC provides the information and technical support necessary to ensure the appropriate coupling selection was made relative to the product specifications. The end user is ultimately responsible for verifying the suitability of the final coupling selection based on the actual service conditions at the time the coupling is installed. Correct installation and alignment practices will ensure longer coupling life, trouble free operation, and a safer operating environment for the coupling.
- d) Please thoroughly review all of the instructions in this document prior to installing this coupling and placing it in operation. Proper safety guidelines and practices should always be followed during every phase of the installation. This installation document is considered part of the purchased product and should be retained for future reference.
- e) If there are any questions, please contact us at [service@psc couplings.com](mailto:service@psc couplings.com). For highly engineered

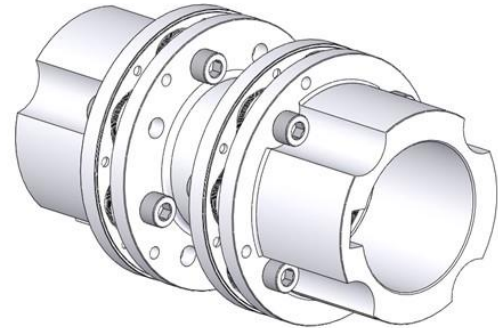


Figure 1 - Series 57 Coupling Size 1058

- couplings or customer specials, PSC will provide an engineering drawing containing special installation instructions that supersede this document.
- f) Look for the following Statements when special care is to be followed and understood:
    - \*\*WARNING\*\*** – This statement means that not following this recommendation could result in bodily harm.
    - \*\*CAUTION\*\*** – This statement means that not following this recommendation could result in a damaged product or equipment.
    - \*\*ATTENTION\*\*** – This is a statement of alert, requiring special attention to a process or measurement require for installation.

### 1) Safety

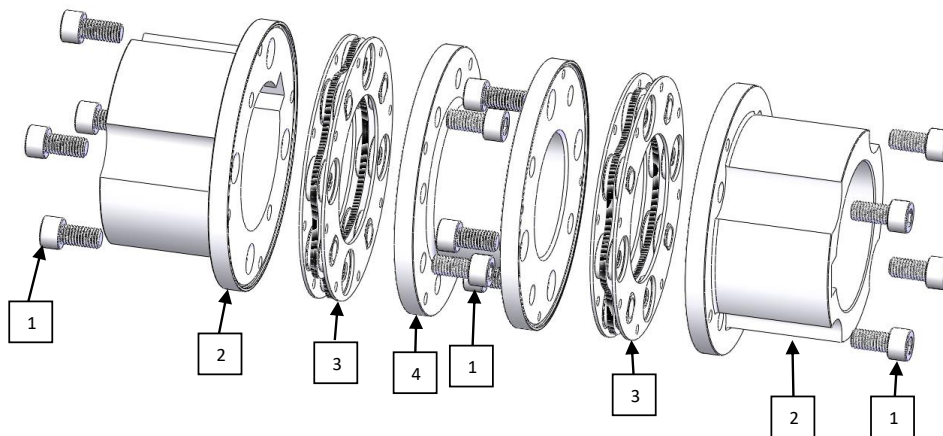
**\*\*WARNING\*\*** Safety is a top priority at PSC. Please pay attention to the following statements:

- a) Accidents involving rotating equipment may result in loss of life, serious bodily harm, or property damage. The purchaser of this equipment must assure that the equipment is properly assembled, installed, safeguarded, operated, and maintained.
- b) This equipment should never be operated at, or subjected to, conditions that exceed manufacturer's specifications. Consult all applicable Federal, State and local laws and regulations covering the safe operation and maintenance of equipment, including, without limitation, the USDOL-OSHA "Lockout/Tag-out" procedure set forth in 29 CFR 1910.147.
- c) Because of the possible danger to persons or property from accidents which may result from the improper use or unapproved modifications of the product, this product must be installed, maintained and operated in accordance with the procedures, standards, and engineering specifications specified in the product literature. To assure safe operation, this product should be inspected in accordance with the instructions described in this document. Proper guards and any suitable safety equipment or procedures as may be necessary, or as may be specified in safety codes, should be installed by the user. Safety equipment, coupling guards, and shields are not provided by, nor are they the responsibility of PSC.
- d) Do not touch any coupling or rotating equipment when it is in operation.
- e) Only skilled professionals should install couplings. These Maintenance and installation instructions should be readily available during the onsite installation of any PSC Series 57 coupling.
- f) During operation all rotating couplings must have coupling guards installed that comply with whatever local standard is the rule of law in the geographical vicinity where the coupling is being installed.
- g) All PSC couplings and replacement parts should be stored in a protected environment to prevent damage which may prematurely compromise the coupling during its life span.
- h) For ATEX requirements the guard must have a minimum of 12.7 mm (1/2 in) radial clearance to the coupling outside diameter and allow for proper ventilation.
- i) Follow all static dissipative requirements when working in sensitive areas. Packaging can hold static charges so be sure to remove outside of critical areas.
- j) Any work done on the coupling must only occur when the coupling has zero stored energy.
- k) Do not engage the drive system without fully assembling all coupling components. If the equipment is started with only

- a hub attached, the hub must be ready for normal operation, with the key and set screw (if included) fastened. When the full coupling assembly is started, all fasteners and hardware must be completely and properly secured.
- l) **\*\*WARNING\*\* DO NOT RUN THE COUPLING WITH OUT ALL FASTENERS TORQUED TO PROPER LEVELS**
  - m) Follow DIN EN 1127-1:2008:02, Annex A. for any explosive tool requirements.
  - n) The coupling may only be used in accordance with the technical data provided in the PDC disc coupling catalog.
  - o) **\*\* WARNING \*\* DO NOT MODIFY ANY PART OF THE SERIES 57 PSC DISC COUPLING FOR ANY REASON**
  - p) Any spare parts for service or replacement must come from or be approved by PSC.

Table 1 – PSC Series 57 Coupling Component Part Numbers

Coupling Assembly	Socket Head Cap Screws -1-	Hubs * -2-	Disc Pack -3-	Center Member -4-
57-516	CLS 12.9 M5-0.8 x 12mm Lg.	100026	100016	100007
57-696	CLS 12.9 M6-1.0 x 16mm Lg.	100020	100010	100001
57-906	CLS 12.9 M8-1.25 x 20mm Lg.	100027	100017	100008
57-1058	CLS 12.9 M10-1.5 x 20mm Lg.	100021	100011	100002
57-1358	CLS 12.9 M12-1.75 x 25mm Lg.	100022	100012	100003
57-1708	CLS 12.9 M16-2.00 x 35mm Lg.	100023	100013	100004
57-2048	CLS 12.9 M20-2.50 x 40mm Lg.	100024	100014	100005
57-2558	CLS 12.9 M24-3.00 x 55mm Lg.	100025	100015	100006
57-3008	CLS 12.9 M30-3.50 x 70mm Lg.	100028	100018	100000
57-3438	CLS 12.9 M36-4.00 x 80mm Lg.	100029	100019	100009
57-4048	CLS 12.9 M42-4.50 x 100mm Lg.	100120	100090	100080
57-4628	CLS 12.9 M48-5.00 x 110mm Lg.	100121	100091	100081



\*All hub part numbers are rough bored.

## 2) Hub Mounting

- a) Inspect the coupling assembly in order to insure no visible damage is present.
- b) Clean the hub bores and shafts using lint free cloth and a light solvent or degreaser. Remove any nicks or burrs.
- c) The key stock should have a snug fit in the hub and shaft, with a slight clearance over the top of the key stock when assembled.
- d) **\*\*CAUTION\*\*** Oven Heating is the preferred method. Parts can be heated to higher temperatures, usually 450° F to 600° F (235° C to 315° C). 600° F is the maximum temperature where the steel hub does not go through an annealing process and yet can still be handled with heat resistant gloves. When heating the hubs in an oven, place them on a rack and do not rest the hubs on the oven surface. The hubs should remain in the oven for a sufficient period of time to heat the hub all the way through.

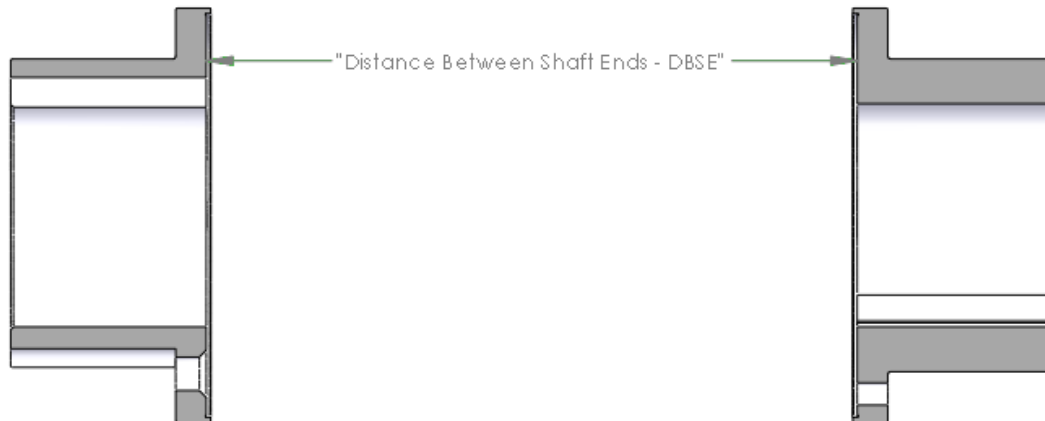


Figure 2 – Mounting Hubs on Shafts

- e) **\*\*WARNING\*\*** Open Flame Heating is typically not recommended. If the hub is being heated with an oxyacetylene, or blow torch, use an excess acetylene mixture. Mark the hub body at the top, center, and bottom along the length of the hub with heat resistant crayons, one with a 350° F (177° C) melt temperature and another with a 450° F (232° C) melt temperature. The hub should be sitting elevated on refractory bricks oriented to allow the flame to flow through the hub. With a “Blue Flame” or “Rosebud” torch, direct the flame towards the hub bore using constant motion to avoid overheating any single area. Once the heat sensitive crayon marks melt, the hub should be ready for mounting.
- f) Higher temperatures may be required for higher interference fit levels where alloy steel hubs may be encountered. A general rule to consider is that for every 160°F increase in temperature, steel will expand 0.001 inch for every inch of shaft diameter (or 0.029 mm/100°C). When calculating temperatures, also consider additional expansion to provide clearance and allow for a loss of heat and subsequent shrinkage during the handling process.

3) **Straight Bore with Clearance/Slip Fit**

- a) Install the key stock in the shaft and check to make sure the set screw is not protruding into the keyway. Then slide the hub up the shaft till flush to the shaft end.
- b) Assemble and tighten the set screw(s) using a calibrated torque wrench to the values shown in Table 2.
- c) **\*\*CAUTION\*\*!** Never use two set screws with one on top of the other in the same tapped hole.

Table 2 – Set Screw Tightening Torque

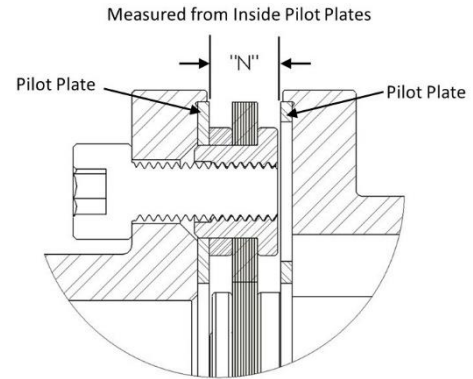
<b>Set Screw Size</b>	#10-32	1/4-20	3/8-16	1/2-13	5/8-11	3/4-10	1-8
<b>Hex Head Key Size</b>	3/32	1/8	3/16	1/4	5/16	3/8	9/16
<b>Tightening Torque</b>	(Nm)	4.5	10.6	35	84	165	902
	(ft-lb)	3.3	7.8	26	62	122	665
<b>Set Screw Size</b>	M5	M6	M10	M12	M16	M20	M24
<b>Hex Head Key Size</b>	2.5	3	5	6	8	10	12
<b>Tightening Torque</b>	(Nm)	4.7	7.7	35	55	125	425
	(ft-lb)	3.5	5.7	26	41	92	313

4) **Straight Bore with Interference Fit**

- a) Accurately measure the bore and shaft diameters to assure a proper interference fit.
- b) Install the key in the shaft.
- c) Follow hub heating options in section 2.
- d) With the hub thermally expanded, install on to the shaft so the pilot bore is flush with the end of the shaft.

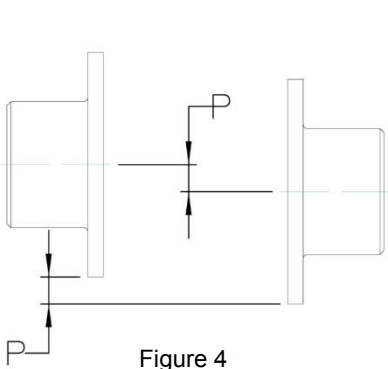
5) **Shaft Alignment**

- a) **\*\*ATTENTION\*\*** To maximize the life of the disc packs, the shafts must be aligned to minimize flexing of the coupling discs. Follow Table 3 for alignment values.
- b) Shim the drivetrain to meet the alignment values in table 3. After alignment values are achieved, the discs in the disc packs should not have evidence of waviness. This waviness is a symptom of axial stress which can be corrected by fine tuning the distance between shaft ends or repositioning the hubs on the shafts.
- c) The minimum and maximum values for dimension "N" shown in Figure 3 are given in Table 3. These dimensions are recommended for initial installation. Additional capacity is available to compensate for any application driven thermal and structural equipment movement. Maximum axial capacity is also shown in Table 3.

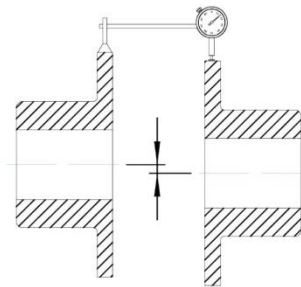


**Figure 3 – Disc Gap**

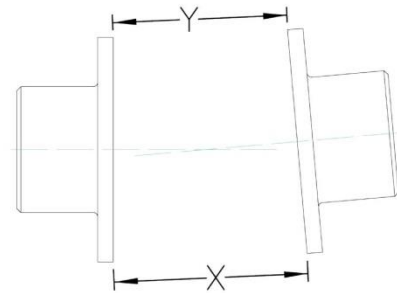
Figure 4 is parallel offset with equals TIR divided by 2. Figure 5 is TIR for parallel misalignment. Figure 6 is angular misalignment across the entire coupling.



**Figure 4**



**Figure 5**



**Figure 6**

**Table 3 – Alignment Values**

Model	Outer Dia		"N" Dimension (Gap between inside Pilot Plates) (Fig. 3)						DBSE		Axial Misalignment Capacity +/- (mm)		Recommended Initial Alignment Limits ***					
	A Dim (in)	A Dim (mm)	N min (in)	N nom (in)	N max (in)	N min (mm)	N nom (mm)	N max (mm)	STD "C" (in)	STD "C" (mm)			Parallel Misalignment Maximums				Max Angular (X-Y) (in) (mm)	
											TIR (in)*	TIR (mm)*	P (in)**	P (mm)**				
516	2.73	69.30	0.236	0.240	0.245	6.0	6.1	6.2	3.50	88.9	0.018	0.46	0.031	0.78	0.015	0.39	0.024	0.61
									3.94	100.0			0.034	0.87	0.017	0.44		
									5.00	127.0			0.044	1.11	0.022	0.55		
									5.51	140.0			0.048	1.22	0.024	0.61		
696	3.50	88.90	0.289	0.295	0.301	7.3	7.5	7.6	3.50	88.9	0.024	0.61	0.031	0.78	0.015	0.39	0.031	0.78
									3.94	100.0			0.034	0.87	0.017	0.44		
									4.38	111.3			0.038	0.97	0.019	0.49		
									5.00	127.0			0.044	1.11	0.022	0.55		
									5.51	140.0			0.048	1.22	0.024	0.61		
									7.09	180.0			0.062	1.57	0.031	0.79		
906	4.64	117.90	0.377	0.385	0.393	9.6	9.8	10.0	3.50	88.9	0.031	0.79	0.031	0.78	0.015	0.39	0.040	1.03
									3.94	100.0			0.034	0.87	0.017	0.44		
									4.38	111.3			0.038	0.97	0.019	0.49		
									5.00	127.0			0.044	1.11	0.022	0.55		
									5.51	140.0			0.048	1.22	0.024	0.61		
									7.09	180.0			0.062	1.57	0.031	0.79		
1058	5.40	137.20	0.381	0.390	0.399	9.7	9.9	10.1	4.38	111.3	0.036	0.91	0.038	0.97	0.019	0.49	0.047	1.20
									5.00	127.0			0.044	1.11	0.022	0.55		
									5.51	140.0			0.048	1.22	0.024	0.61		
									7.09	180.0			0.062	1.57	0.031	0.79		
									7.50	190.5			0.065	1.66	0.033	0.83		
									8.00	203.2			0.070	1.77	0.035	0.89		
1358	6.88	174.60	0.483	0.494	0.506	12.3	12.5	12.8	5.00	127.0	0.046	1.17	0.044	1.11	0.022	0.55	0.060	1.52
									5.51	140.0			0.048	1.22	0.024	0.61		
									7.09	180.0			0.062	1.57	0.031	0.79		
									7.50	190.5			0.065	1.66	0.033	0.83		
									8.00	203.2			0.070	1.77	0.035	0.89		
									9.84	250.0			0.086	2.18	0.043	1.09		
1708	8.69	220.70	0.587	0.601	0.616	14.9	15.3	15.6	7.09	180.0	0.058	1.47	0.062	1.57	0.031	0.79	0.076	1.93
									7.50	190.5			0.065	1.66	0.033	0.83		
									8.00	203.2			0.070	1.77	0.035	0.89		
									9.00	228.6			0.079	1.99	0.039	1.00		
									9.84	250.0			0.086	2.18	0.043	1.09		
									12.00	304.8			0.105	2.66	0.052	1.33		
2048	10.63	269.90	0.723	0.740	0.758	18.4	18.8	19.2	7.09	180.0	0.070	1.78	0.062	1.57	0.031	0.79	0.093	2.36
									7.50	190.5			0.065	1.66	0.033	0.83		
									8.00	203.2			0.070	1.77	0.035	0.89		
2558	12.94	328.68	1.028	1.050	1.072	26.1	26.7	27.2	9.84	250.0	0.088	2.24	0.086	2.18	0.043	1.09	0.113	2.87
									15.00	381.0			0.131	3.32	0.065	1.66		
									15.75	400.0			0.137	3.49	0.069	1.75		
3008	15.46	392.76	1.409	1.435	1.461	35.8	36.4	37.1	18.00	457.2	0.103	2.62	0.157	3.99	0.079	1.99	0.135	3.43
									19.69	500.0			0.172	4.36	0.086	2.18		
									18.00	457.2			0.157	3.99	0.079	1.99		
3438	17.63	447.68	1.622	1.651	1.681	41.2	41.9	42.7	19.69	500.0	0.118	3.00	0.172	4.36	0.086	2.18	0.154	3.91
									18.00	457.2			0.157	3.99	0.079	1.99		
									19.69	500.0			0.172	4.36	0.086	2.18		
4048	20.88	530.23	1.860	1.895	1.930	47.3	48.1	49.0	24.00	609.6	0.139	3.53	0.209	5.32	0.105	2.66	0.182	4.63
									23.62	600.0			0.206	5.24	0.103	2.62		
									24.00	609.6			0.209	5.32	0.105	2.66		
4628	23.75	603.25	2.340	2.380	2.420	59.4	60.5	61.5	23.62	600.0	0.159	4.04	0.206	5.24	0.103	2.62	0.207	5.26
									24.00	609.6			0.209	5.32	0.105	2.66		

\* Parallel Misalignment measured by rotating the hubs with a dial indicator on the outside hub diameter will result in a maximum TIR.  
 \*\* Parallel Offset "P" is equivalent to one-half of the TIR measurement using dial indicators.  
 \*\*\* During operation do not exceed the maximum misalignment capacity of coupling. For all sizes, maximum misalignment capacity of coupling is 1/2° per disc pack.

### 6) Final Assembly

- a) Verify that the hubs have been mounted as shown in Figure 2 to provide the correct "C" length. The "C" length is the distance measured between the faces of the two mounted hub flanges.
- b) If your coupling assembly has a non-standard "C" length, refer to assembly drawing of coupling to obtain the appropriate "C" length. Any disc packs fastened with correct torques to the center member should stay fastened.

- c) **\*\*CAUTION\*\*** CLEAN & DEGREASE THE HUB & CENTER SPOOL PILOT FACES PRIOR TO INSTALLATION OF THE DISC PACKS
- d) **\*\*WARNING\*\*** DO NOT COAT THE HUB AND CENTER SPOOL PILOT FACES WITH ANY PLATING, PAINT, EPOXY, OR ANY OTHER SURFACE TREATMENT WITHOUT APPROVAL FROM PSC.
- e) Due to the hub-disc pack-center member piloting feature, the center member subassembly must be compressed to allow it to be slipped between the two end hubs. Use the hub side socket head cap screws to compress the center member assembly by inserting them through the holes in

the flanges of the center spool and threading them into the disc pack in the opposite direction they would have been installed from the hub side. See Figure 7.

- f) **\*\*CAUTION\*\*** Because of the precision fit required to align the coupling, the pilot plates may need to be lightly tapped

into place using drift pins. The pilot plates need to be seated inside the pilot bore on both hubs and center member.

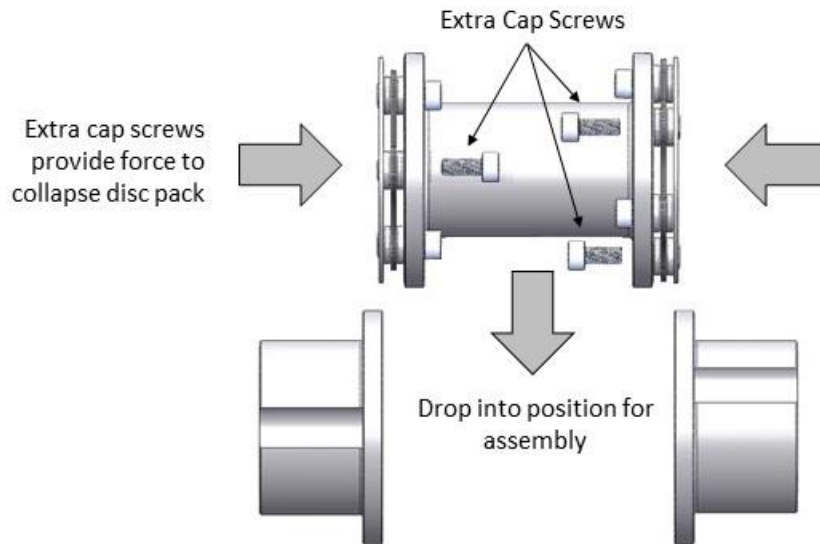


Figure 7

- g) Once the center member assembly is in place and piloted inside the hub, loosen the bolts that were used to compress the disc pack and seat the disc packs firmly inside of the hub pilots.
- h) Use the bolts that were just loosened and removed from the compression of the center member to tighten the disc pack from the hub side.
- i) Apply clean motor oil to the bolt threads and turn until hand tight.
- j) Proceed to the other end of the coupling. Repeat steps 6.3 thru 6.4 for the other side of the coupling.
- k) **\*\*ATTENTION\*\*** Slightly tighten all Cap screws using an alternating progressive pattern on each disc pack as shown in

Figures 9 and 10 making sure the disc pack is not distorted and all the bolts are fully seated. Tighten each socket head cap screw to the appropriate torque value shown in **Table 4**, using an incremental torque in a progressive alternating pattern as shown in Figures 9 and 10. A progression of 20% of the tightening torque for each progression is recommended. Please use **Table 5** for recommended torque specifications for all other fasteners in the coupling (for example, or flywheel rings or adapters)

l) As a guide, measure the distance between flanges known as dimension "N" shown in Figure 3 and given in Table 3.

m) **\*\*CAUTION\*\*** Remove any dust deposits from the coupling components and the coupling elements in an appropriate way for explosive environments.

**Important Note on Disc Pack Orientation:**

- n) The bushing heads should be opposite the counter sinks in the hub and center member flanges. See Figure 8.
- o) This allows the barrel end of the bushing to pull freely into the counter sink to make a strong clamping force on the disc pack.

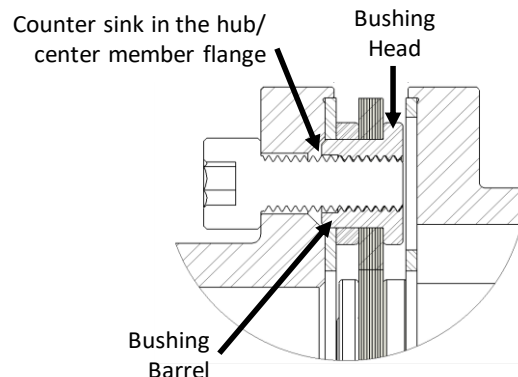


Figure 8

**7) Disc Pack Replacement**

- a) If it becomes necessary to replace the disc packs, it can be done as follows:

- b) Remove the center member subassembly by removing all socket head cap screws from the hubs as defined in Section 6, compress the center member assembly by inserting the cap screws through the holes in the flanges of the center spool and threading them into the disc pack tapped holes. This will allow the center member assembly to drop out from between the hubs.
- c) Install the new disc packs to the center spool first then follow the steps in section 6 to complete installation.
- d) It is recommended that all socket head cap screws have their tightening torque checked after several hours of initial operation. Note: Center member subassemblies may have their socket head cap screws factory tightened. On center member subassemblies where the spacer length is short and wrench access is limited, special wrenches are used to tighten the socket head cap screws. Consult PSC for assistance in obtaining special wrenches.

Table 4 – SHCS \ Drive Bolt Tightening Torque for Disc Packs Only

Series 57 Coupling Size	"A" Dimension Std Hub		Socket Head Cap Screw CLS 12.9			Wrench Size (in)
			Bolt Size (mm)	Torque*		
	(in)	(mm)		(ft-lb)	(Nm)	
516	2.73	69.3	M5 x 12mm	8.5	11.5	4
696	3.50	88.9	M6 x 16mm	15	20	5
906	4.64	117.9	M8 x 20mm	34	46	6
1058	5.40	137.2	M10 x 20mm	66	90	8
1358	6.88	174.8	M12 x 25mm	106	144	10
1708	8.69	220.7	M16 x 35mm	265	359	14
2048	10.63	270.0	M20 x 40mm	515	698	17
2558	12.94	328.7	M24 x 55mm	887	1202	19
3008	15.46	392.7	M30 x 70mm	1786	2421	22
3438	17.63	447.8	M36 x 80mm	3113	4221	27
4048	20.88	530.4	M42 x 100mm	4983	6756	32
4628	23.75	603.3	M48 x 110mm	7539	10222	36

\* Note: These torque values are maximums for Holo-Krome (or equivalent) CLS 12.9 coarse bolts with lubricated threads.

**A NOTE ON TIGHTENING TORQUE:** The torque values assume lubrication of the threads with a light oil. If something other than a light oil is used, please contact PSC Couplings for revised tightening torque values.

Follow the numbered torque pattern below during installation.

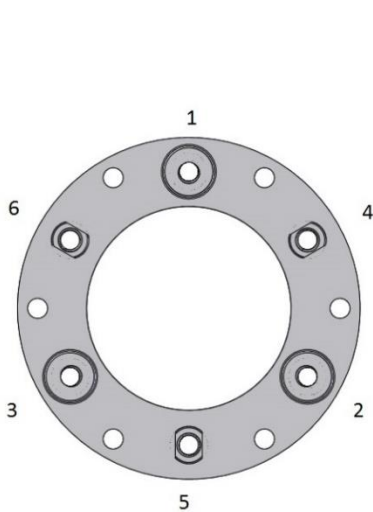


Figure 9

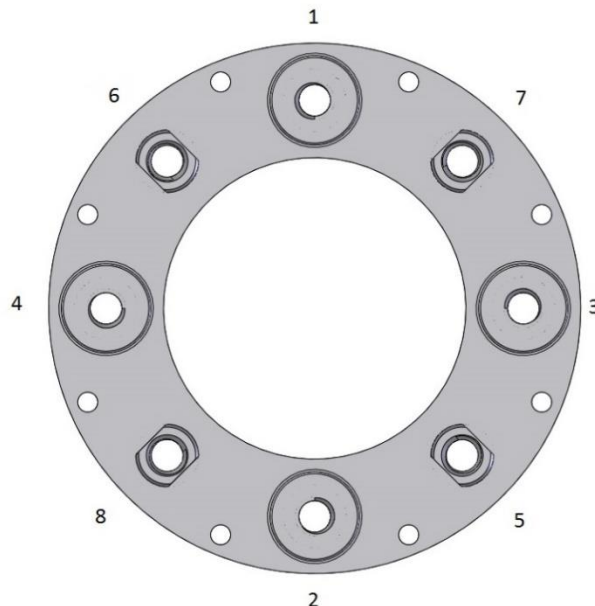


Figure 10

Table 5 – Recommended Torque Specifications for All Other Fasteners (Other than for Disc Packs and Set Screws)

Bolt Size (mm)	Torque*	
	(ft-lb)	(Nm)
M5	4.9	6.7
M6	8.3	11
M8	20	27
M10	40	54
M12	70	95
M16	173	235
M20	337	458
M24	582	792
M30	1158	1575
M36	2024	2753

\* Note: These torque values are maximums for CLS 10.9 fasteners with lubricated threads.

**A NOTE ON TIGHTENING TORQUE: The torque values assume lubrication of the threads with a light oil. If something other than a light oil is used, please contact PSC Couplings for revised tightening torque values.**

Table 6 – Recommended Set Screw Torque Specifications

Set Screw Size	Torque	
	(ft-lb)	(Nm)
M4	1.5	2.1
M5	3.5	4.7
M6	5.7	7.7
M8	13	18
M10	26	35
M12	42	57
M16	93	126
M20	186	252
M24	310	420